

15W LED A19 照明散热模组产品

- 最佳声音品质
- 延长LED灯泡使用寿命
- 高可靠度

规格	
机型	TA001-09012
模组尺寸 (mm)	φ 59 x 20.53
重量 (g)	48.0
热阻值 (°C / Watts)	1.2
散热模组噪音 @1M, dB(A)	16.8
额定电压 (V)	5
功耗 (W)	0.21
风扇转速(加上散热鳍片), (RPM)	3800
散热鳍片材料	ADC12
安规	UL / CUR / TUV / CE

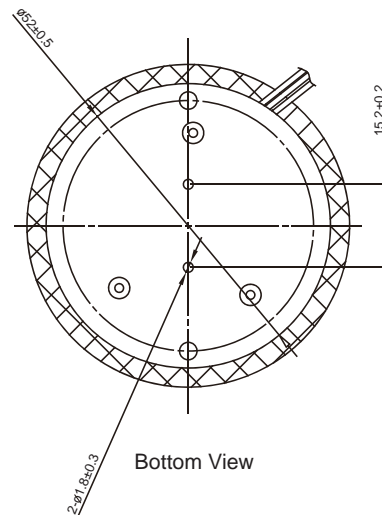
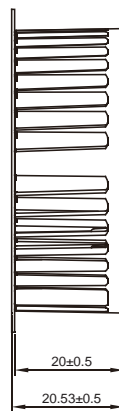
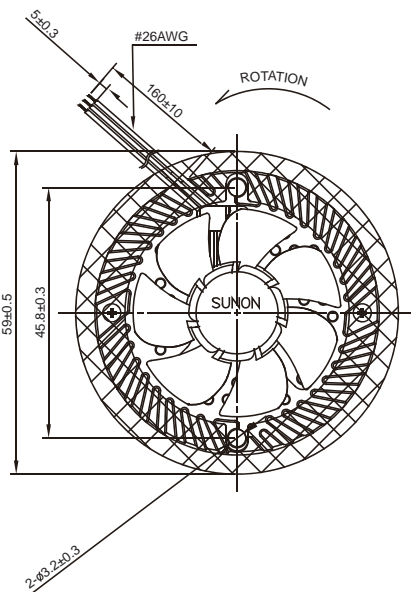

UNIT: mm